



Welcome to February Newsletter from Jotron SKIPPER!

Jotron and Jotron SKIPPER at APM 2024 in Singapore:

Jotron and Jotron SKIPPER will join forces and be ready for you during APM 2024 in Singapore. The venue will take place at 13.-15. March. Please visit us at our stand E-P48!

To pre-book a meeting with Jotron please contact your area sales manager or send an e-mail to: sales@jotron.com.

To pre-book a meeting with Jotron SKIPPER please send an e-mail to sales.skipper@jotron.com.



Jotron SKIPPER with new retrofit adaptor for Furuno Sea Valve:

SKIPPER DL2 will now also be available with a special sensor adaptor to fit Furuno Sea Valves used for DS50 and DS60. The existing Furuno Sea Valve will then be able to re-use, so no need for a diver or dry-dock to do the retrofit.

The following products are needed:

- [CU-M001-SB](#) DL2 PanelPC 9inch touch display
- [JB70D2-SA](#) Electronic Unit for DL2 Dual Axis Doppler Speed Log
- [JB12-SA](#) Junction box, 12 pole
- [DL2SF-SA](#) DL2 sensor for DS-630 in DS-661 for Furuno DS-60

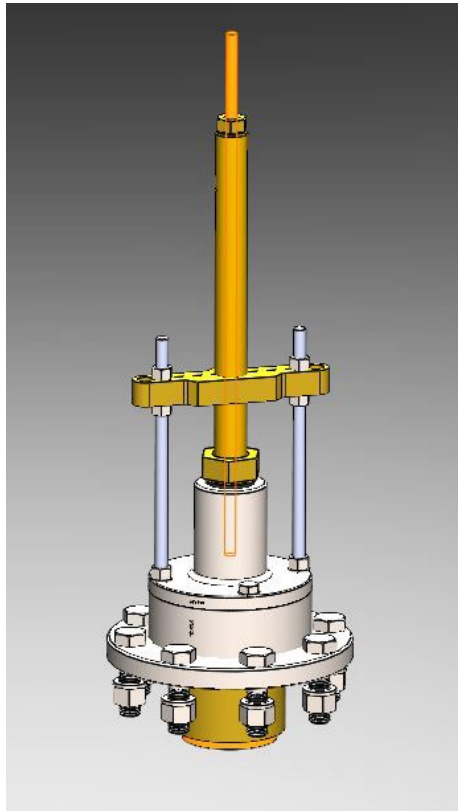

Tron SA20 PLB Safety Alert Personal Locator Beacon:

Tron SA20 PLB has a global emergency alert coverage. This PLB can be used in worldwide offshore (maritime) and onshore (land based) applications. Tron SA20 PLB has a rugged and compact design, and is one of the smallest 406MHz lifesaving devices on the market.

Features:

- 10 year battery lifetime
- 406/121.5 MHz
- Return Link Service (RLS)
- GNSS and MEOSAR
- LED and IR-LED flash
- NFC, mobile APP connectivity

The Tron SA20 PLB will be available for purchase in Q1 2024!

[Read more here!](#)

Please contact sales@jotron.com for your quotation.



SKIPPER technical training 2024:

Training topics:

Basics, installation and service of all present SKIPPER speed logs and Echo sounders. ESN100, ESN200, DL1, DL2, DL21, EML224, EML1100, 1200, SL1200

Introduction and installation of next generation Displays and Electronic units planned to be released in 2024.

The first units to be released are the EML speed logs EML1200/EML1100/EML2

Training plan 2024:

March 13th-15th: Busan, South Korea - Jaeun Corporation - Fully booked!

June: Newcastle, UK

September 9th-11th.: Norway, Oslo. Jotron SKIPPER

September: Italy

November: Dubai, UAE

The duration for all training courses are 3 days.

For registration please email support.skipper@jotron.com

Jotron SKIPPER with new e-mail addresses:

We have now changed all our e-mail addresses. In general it is always firstname.lastname@jotron.com.

Common e-mails:

sales.skipper@jotron.com

support.skipper@jotron.com

finance.skipper@jotron.com

admin.skipper@jotron.com

development.skipper@jotron.com

production.skipper@jotron.com

purchasing.skipper@jotron.com

qa.skipper@jotron.com

SKIPPER marketing videos:

SKIPPER has now produced several videos to be used freely on stands in exhibitions etc.

[For SKIPPER marketing video click here!](#)

[For short silent product presentation click here!](#)

[For complete silent product presentation click here!](#)

Please contact sales.skipper@jotron.com for high resolution versions.

Jotron SKIPPER AS | Enebakkveien 150, 0680, Oslo, Norway |

+47 23 30 22 70 | www.skipper.no